

Request for Qualifications

Nebraska Hall of Fame | Bust of Malcolm X



RFQ Submission Deadline: March 23, 2023

Total Budget Range: \$36,000 - \$46,000

About the Nebraska Hall of Fame

The Nebraska Hall of Fame was established in 1961 to officially recognize prominent Nebraskans. The Hall of Fame honors people who were born in Nebraska, who gained prominence while living in Nebraska, or whose residence in Nebraska was an important influence on their lives and contributed to their greatness. The Bust of Malcolm X, as a Hall of Fame member, will be displayed in the State Capitol in Lincoln, NE. The Capitol contains elaborate mosaics, murals, and sculptures and is active with government business as well as student group tours and other events.

The Nebraska Hall of Fame has specifications for the size of the sculpture and pedestal, included on pages 5 and 6, respectively. After the artist has been selected and has completed different stages of the bust, the Selection Committee will visit the the selected artists' studio to review and comment about the full-sized clay maquette of the bust toward the goal of approving the maquette for casting production. The Committee may choose to approve the maquette pending minor alterations or upon Committee approval of more substantial changes. Once the bust is completed and shipped by the artist and received at the State Capitol, the Nebraska Hall of Fame Commission will schedule an unveiling ceremony with the artist present.

The material of the busts must be bronze, and should be completed in such a way that it harmonizes with the other busts in the Hall of Fame. The artist is responsible for shipping the bust to the Nebraska Capitol, and the pedestal and plaque will be provided by the Office of the Capitol Commission.

For more information about the Nebraska Hall of Fame and the past NE Hall of Fame inductees: <https://history.nebraska.gov/nebraska-hall-of-fame/>

About Malcolm X

Malcolm X is revered as a human rights strategist across the world, and whose life has had an encouraging impact on people from many walk of life. Researchers have documented his travels and level of influence across the globe. Realizing the significance of such recognition, it is important that this bust reflects not only the physical stature of Malcolm, but his moral character as well. The Committee would like to capture Malcolm X as he was in his 30s – a strikingly handsome and poised young man, standing at 6'4" with broad shoulders. His hair was always neat and his beard trimmed. For additional images of Malcolm we recommend referencing the book *The Great Photographs* by Thulani Davis (published 1993). The Committee would like the bust of Malcolm X to embody his characteristics: Upright, confident, kind, thoughtful, disciplined, compassionate, humanitarian, dynamic, empowering, transformative, family.

Finalists will be encouraged to visit the Malcolm X Foundation in Omaha, Nebraska for further research, and can easily schedule a virtual or in-person tour via the website: <https://www.malcolmxfoundation.org/hours-admissions> - (please describe your status as an "artist applicant" in the "special requests" section of the form.)

To learn about the connection of Malcolm X to Omaha and his origins please visit the Nebraska Hall of Fame website: <https://history.nebraska.gov/malcolm-x-selected-to-nebraska-hall-of-fame/>

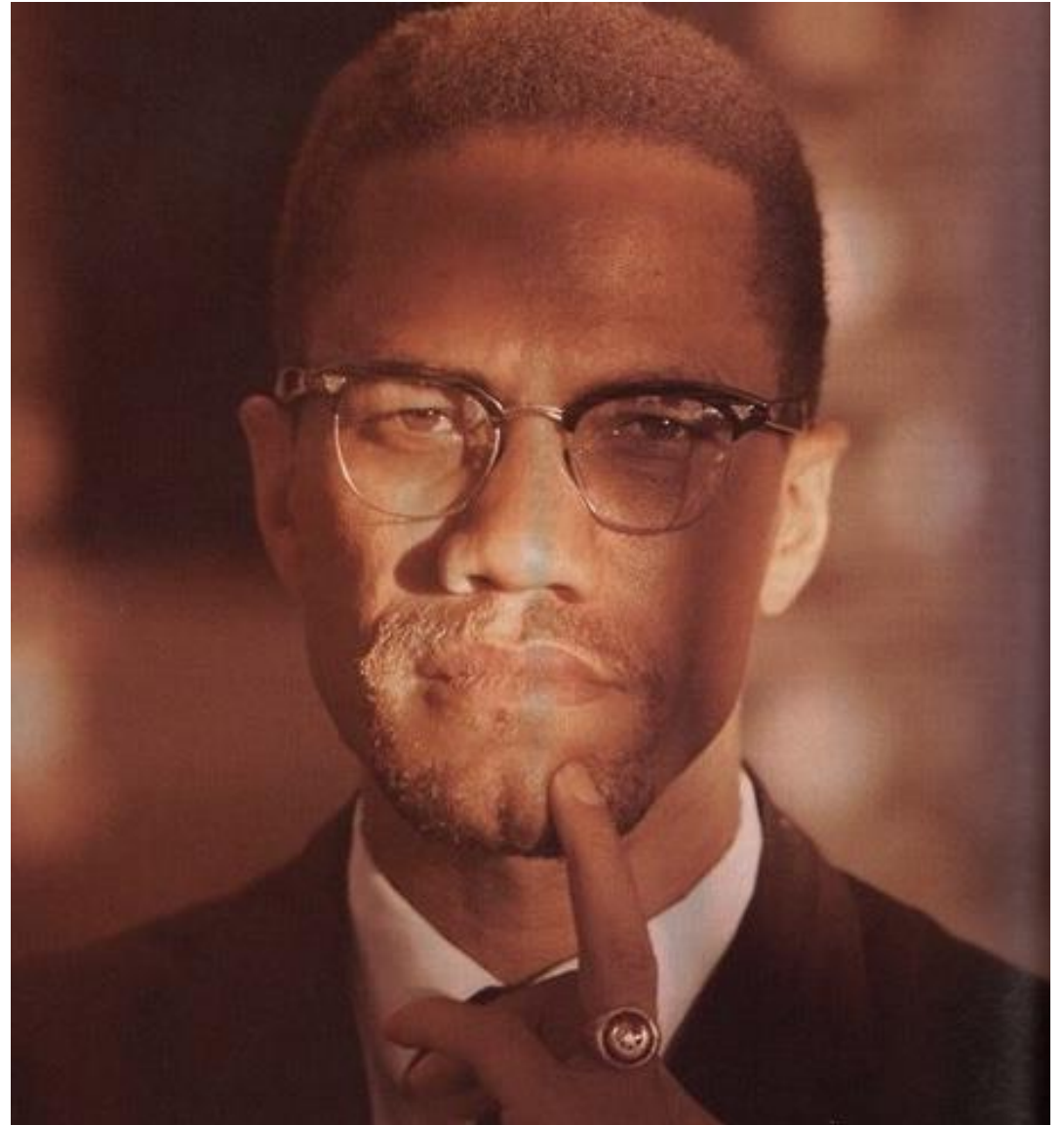

The Committee is most interested in the artist's portrayal of Malcolm X based on these photographs.

Selection Process

The Nebraska Hall of Fame Selection Committee for the Malcolm X bust, in consultation with the Nebraska Arts Council, has full oversight for the selection of an artist for this project. Professional public artists/teams within the U.S. are eligible. The Committee reviews RFQ submissions on SlideRoom. Finalists will receive a presentation honorarium and a travel stipend, if applicable. Finalist presentations should include concept, design, detailed budget for the available funds, projected maintenance, etc.

Budget

A range \$36,000 to \$46,000.00 is allocated for this project. The Committee will not necessarily give preference for a project budget that requires less money. All expenses for the selected design and commission are the responsibility of the artist/team, including but not limited to: travel/lodging, fabrication and supplies, insurance and shipment of the bust to the Nebraska State Capitol. The Office of the Capitol Commission will provide the pedestal, plaque and installation.

Selection Criteria

Letter of Interest: clarity of conceptual approach and connection to this project. Work Samples: evidence of ability to complete similar projects from prior artwork and of the artist's mastery in bronze.

Timeline *subject to change.

RFQ Open:	February 3, 2023
Submission Deadline:	March 23, 2023
Finalists Notified:	March 31, 2023
Proposal Presentations:	May 22-25, 2023
Artwork Installed, by or before:	May 2024

Application Requirements

Submit materials on SlideRoom: nebraska.slideroom.com

Visual Support Materials

Image descriptions: Label each uploaded image with title, medium, year, project budget, and any relevant description.

Images: Ten (10) jpg images of completed relevant artworks.

Video: Optional video file may demonstrate moving parts, time-based work, functionality, etc. (mov, wmv, or flv files, no larger than 60MB each, nor longer than five minutes each.)

Required Materials

CV/Resume: Limit to three pages.

Three Professional References: Complete contact information for references with a deep knowledge artwork and work methods, and for which project they worked with you.

Letter of Interest: Briefly describe your connection to or interest in creating the bust of Malcolm X for the Nebraska Hall of Fame, how you have completed similar projects to embody someone in bronze sculpture, and relevant past completed projects and how they relate to this project. Use 500 words or less.

Application Fee: \$10 via the secure payment system on SlideRoom.

Contact

Meagan Dion, Public Art and Artist Programs Specialist
Nebraska Arts Council, meagan.dion@nebraska.gov

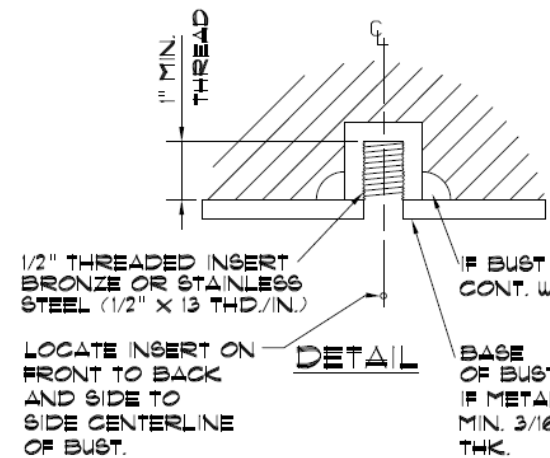
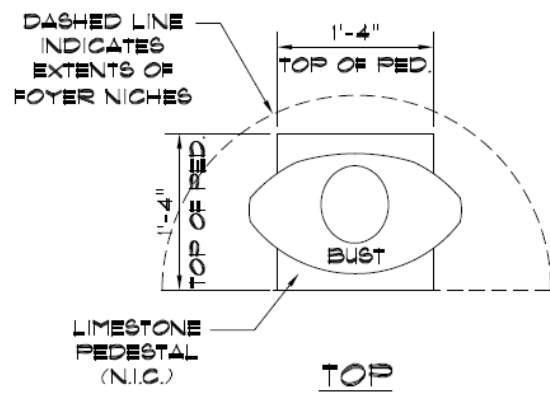
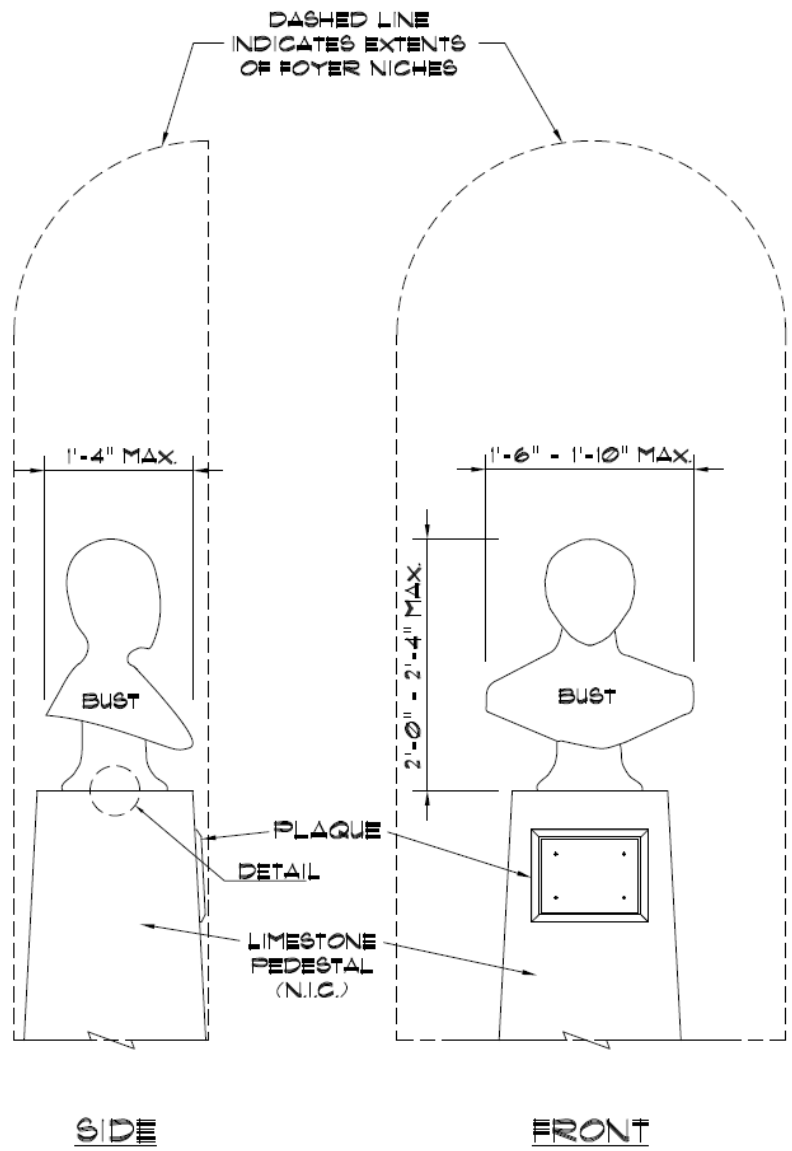

HALL OF FAME BUST REQUIREMENTS

1. SCULPTOR SHALL SUBMIT SKETCH(ES) AND/OR SHOP DRAWINGS OF BUST FOR APPROVAL OF NEBRASKA HALL OF FAME COMMISSION AND THE OFFICE OF THE CAPITOL COMMISSION PRIOR TO ANY FINAL CASTING OR FABRICATION. PROPOSED FINISH(ES) SHALL ALSO BE NOTED ON SKETCHES AND SAMPLES SUBMITTED WITH DRAWINGS FOR APPROVAL.
2. NO HALL OF FAME BUST TO BE LARGER THAN LIFE SIZE.
3. DEVIATIONS IN FINAL BUST (FROM APPROVED SKETCHES NOTED ABOVE) OR EXCEEDING MAXIMUM DIMENSIONS SHOWN ON THIS DRAWING MAY CONSTITUTE REJECTION OF FINAL BUST REQUIRING SCULPTOR TO RECONFIGURE AND/OR RECAST ENTIRE BUST TO CONFORM TO APPROVALS OR STANDARDS NOTED.

**NEBRASKA
HALL OF FAME
BUSTS**
NO SCALE

HALL OF FAME PEDESTAL
NEBRASKA CAPITOL RCR/12-91

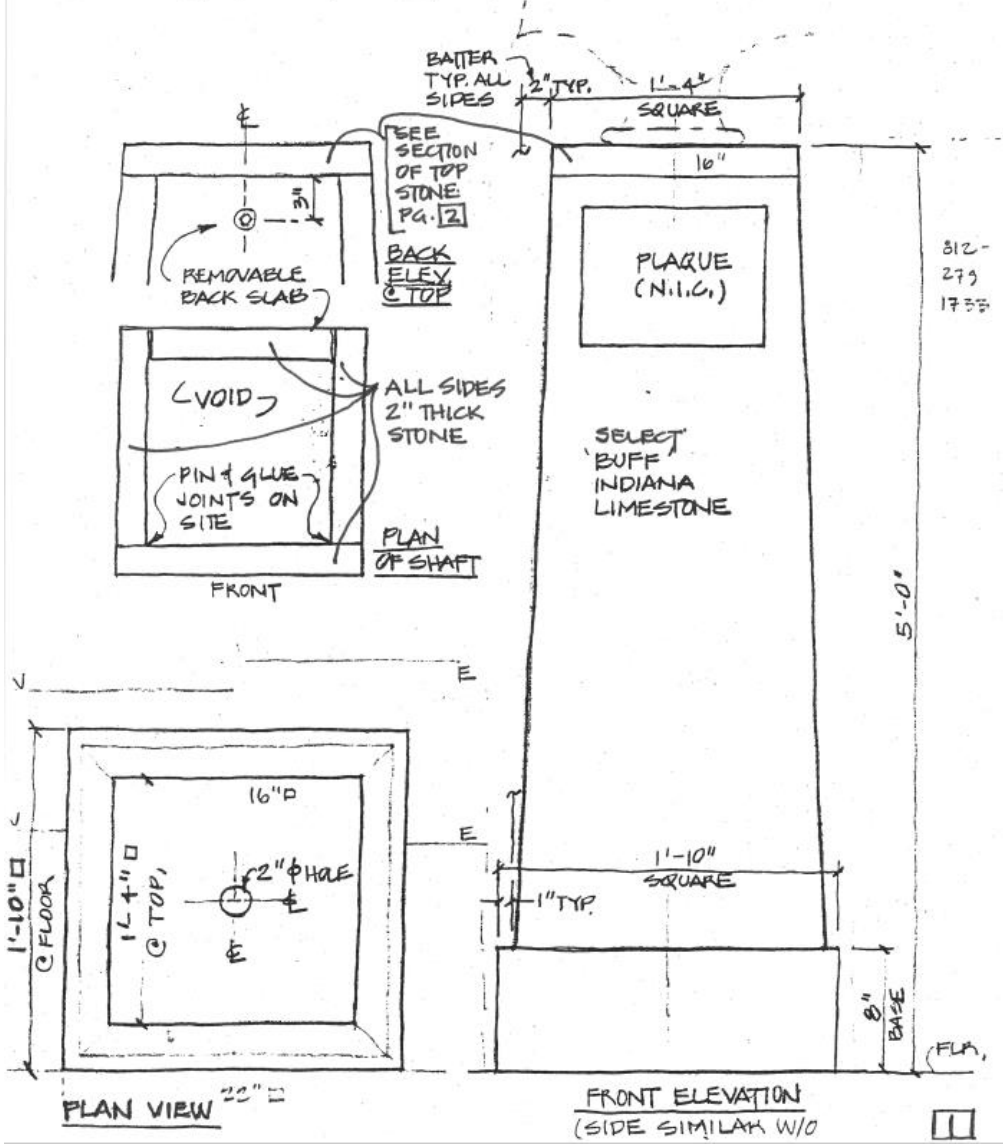

HALL OF FAME PEDESTAL
NEBRASKA CAPITOL RCR/12-91

APPROVED AS STANDARDS BY
NE. HALL OF FAME COMMISSION
9-14-92

